

CERTIFICATE OF APPROPRIATENESS APPLICATION MAJOR WORK

APPLICATION SUBMITTAL REQUIREMENTS

- Applications are due by 1:00 PM and are submitted by appointment only. Please call 910-254-0900 to schedule an appointment
- Do not drop off, email or mail in an application for major work.
- Application fees must be paid at the time of submission. If you wish to pay over the phone, please call 910-254-0900 to make arrangements for credit card payments
- Applications will be reviewed for completeness before they are accepted. Incomplete applications will not be scheduled for HPC review.
- A pre-application meeting is required for all major works applications; applications cannot be accepted without a pre-application meeting. Meetings may be scheduled by calling 910-254-0900.
- All applicable items listed on the submittal checklist are required for an application to be considered complete.

Historic Preservation Commission Meetings

Meeting Date	Submission Deadline
January 11	12/05/2023
February 8	01/03/2024
March 14	02/06/2024
April 11	03/05/2024
May 9	04/02/2024
June 13	05/07/2024
July 11	06/04/2024
August 8	07/03/2024
September 12	08/06/2024
October 10	09/03/2024
November 14	10/08/2024
December 12	11/05/2024
January 9, 2025	12/03/2024

City of Wilmington
 Planning and Development
 Historic Preservation
 929 N Front Street
 1st Floor | P.O. Box 1810
 Wilmington NC 28401

(910) 254-0900
 Preservation@wilmingtonnc.gov

RECEIVED

AUG 05 2024

PLANNING DEPARTMENT

**Approval of After-the-Fact
 (work completed without a
 COA) requires application
 submittal and a fee of
 \$100**

Application Fees

Estimated Project Cost	Application Fee
Up to \$ 17,999	None
\$ 18,000 - \$ 24,999	\$ 20
\$ 25,000 - \$ 49,999	\$ 25
\$ 50,000 - \$ 99,000	\$ 35
\$ 100,000 - \$ 499,000	\$ 50
\$500,000 or more	\$ 100

CERTIFICATE OF APPROPRIATENESS APPLICATION MAJOR WORK

PLEASE TYPE OR PRINT

Street Address: 319 S 5th Ave

Tax Parcel Number: R05405-022-007-000

Property Owner Information

If the applicant is not the property owner, an agent form (below) is required to be signed by the property owner and submitted with an application. Application must be signed by all legal property owners.

Owner name(s): Christopher Santucci + Nicole Santucci

Mailing Address: 319 S. 5th Ave Wilmington, NC 28401

Phone: 910 515 5585 Email address: sauce94@yahoo.com

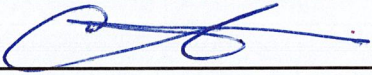
Signature:  and Nicole

Date: 8/3/24

AGENT FORM (This section is required if the applicant is anyone other than the property owner)

I _____ the undersigned owner, do hereby appoint _____ to act on my behalf for the purpose of petitioning the city of Wilmington Historic Preservation Commission for a certificate of appropriateness, as applicable to the property described in the attached petition.

I do hereby covenant and agree with the city of Wilmington that said person (agent) has the authority to do the following acts for or on behalf of the owner:

- Submit property petition and require supplemental materials
- Appear at public meetings to give testimony and make commitments on behalf of the owner
- Accept conditions or recommendations made for the issuance of the certificate of appropriateness on the owner's property
- Act on the owner's behalf without limitations with regard to any and all things directly or indirectly connected with or arising out of any petition for a certificate of appropriate-

This appointment agreement shall continue in effect until final disposition of the petition submitted in conjunction with this appointment.

Owner(s) name(s): _____

Owner(s) signature: _____ Date: _____

Designated agent name: _____

Designated agent address: _____

Designated agent phone: _____ Email address: _____

RECEIVED
AUG 05 2024
PLANNING DEPARTMENT

CERTIFICATE OF APPROPRIATENESS APPLICATION MAJOR WORK

RECEIVED

AUG 05 2024

PLANNING DEPARTMENT

SUBMITTAL CHECKLIST

If the information is not included with the application, the request cannot be scheduled for review by the commission.

Signed Application Form

Agent Form (as needed)

Project Narrative

- Brief detailed description of the project, including a description of how the proposed changes are consistent with the Wilmington Design Standards for Historic Districts

Tax Map

- This can be found online at New Hanover County GIS Portal
- (<https://www.nhcgov.com/844/GIS-Maps-Data>)

Adjacent Property Owners

- List of adjacent property owners with mailing addresses is provided by staff.
- Stamped envelopes addressed to each property owner's mailing address

Proposed Building Materials

- Product sheets for each type of material proposed (including windows, doors, roof, siding, etc.)
- Material Sheet Checklist if applicable
- May include brochures or manufacturer's specification sheets

Digital Photos (all photos may be emailed)

- A keyed site plan or lot diagram showing existing structures, features and conditions
- A close up of the proposed work area.

New Construction, Major Alterations, Additions

These scopes will require additional information including but not limited to the following:

- Site plan, drawn to scale with existing and proposed buildings, setbacks, parking areas, driveways, trees to be removed or preserved, fences and landscaping.
- Architectural drawings, drawn to scale including elevations and floor plans.
- Additional information that helps determine whether the project is consistent with Design Standards.
- Three dimensional models (optional)

The applicant is responsible for supplying all information necessary to enable the Historic Preservation Commission (HPC) to understand the proposal and potential impacts on the historic district or overlay.

Without sufficient information, the Commission may continue or deny the request.

CERTIFICATE OF APPROPRIATENESS APPLICATION

MAJOR WORK

NEW CONSTRUCTION INFORMATION

Complete one sheet for each new building or structure in order to address all of the project components

Building Element	Proposed Materials, Dimensions, Color
Roof (Roof Pitch / Material / Color)	8/12 / Dimensional Shingle / Charcoal
Main Roof	
Front Porch / Side Porch / Rear Porch	
Height (avg. grade to peak of roof)	
Cladding	
Body of building	Engineered wood
Additional (Reveal, Finish, Mortar Color)	
Foundation	
Materials (including color and height)	Galvanized steel joists
Porch (Materials & Dimensions)	
Columns (capital and base)	
Stairs and Railing (include dimensions)	RECEIVED
Decking (floorboards)	
Balustrade / railing (top cap and bottom)	AUG 05 2024
Balustrade - individual balusters	
Ceiling (material, design, dimensions)	PLANNING DEPARTMENT
Screens (only on rear)	
Deck (Materials and Dimensions)	
Posts	
Balustrade / railing (top cap and bottom)	
Balustrade - individual balusters	
Foundation (height and materials)	
Entry steps and railings	
Doors (Materials and Dimensions)	
Front entry	Metal 36 x 80
Sides (specify location)	Metal 72 x 80
Rear	
Windows (Materials, Style, Dimensions)	
Front	
Sides	
Rear	
Gutters and Downspouts	
Driveway	
Dimensions	
Curb, Apron and Runner Materials	
Any Additional Materials	
Install modified Toff Premier Pro shed	Remove bush & grass Shed 8'-0" H x 12'-0" W x 22'-0" L install mulch

RECEIVED
AUG 05 2024
PLANNING DEPARTMENT

Joel Wvshauer



Scott + Katherine Ripley

RECEIVED

AUG 05 2024

PLANNING DEPARTMENT

Narrative

Remove bush from along south property line.
Install shed in South east corner of property
Install mulch between shed and fence.
Southern tree to remain (1'-0" from shed)

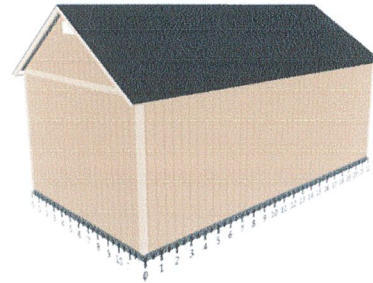

Wall D

Wall A



Wall C

Wall B

PLANNING DEPARTMENT

AUG 05 2024

RECEIVED

Base Details/Permit Details

- Building Size & Style**
Premier Pro Tall Ranch - 12' wide by 22' long
- Paint Selection**
Base: No Paint, Trim: No Paint
- Roof Selection**
Charcoal Dimensional Premium Shingle
- Drip Edge**
White
- Is a permit required for this job?**
Yes, Engineering fees still apply
- Who is pulling the permit?**
Customer

Optional Details

- Special Instructions**
Dormer offset to left on roof B, ~4' from end wall.
- High Wind**
High Wind - Retail
- Doors**
Full-Lite Residential Door (36" x 80") (Left Hand Inswing),
Full-Lite Residential Double Door (72" x 80") (6' x 6'8")
- Walls**
571 Sq Ft House Wrap
- Roof**
360 Sq Ft Roof - 8/12 Roof Pitch Upgrade
Roof - 6' Shed Dormer (10' & 12' Wide)
Roof - 2' Shed Dormer Adder
- Floor and Foundation**
8 Ea Shed Anchor into Dirt - Auger or MR88
- Vents**
2 Ea 16"x8" Wall Vent - White

Jobsite/Installer Details

- Do you plan to insulate this building after Tuff Shed installs it?**
Yes
- Is there a power outlet within 100 feet of installation location?**
Yes
- The building location must be level to properly install the building. How level is the install location?**
Within 4" of level
- Will there be 18" of unobstructed workspace around the perimeter of all four walls?**
Yes
- Can the installers park their pickup truck & trailer within approximately 200' of your installation site?**
Yes
- Substrate Shed will be installed on?**
Grass

SITE PLAN

RECEIVED

AUG 05 2024

PLANNING DEPARTMENT

Joel Warshauer



Scott & Katherine Ripley

18"

BETTER WALLS

Walls Designed for Lasting Durability

- ✓ LP® SmartSide® Engineered Wood Siding Treated to Resist Insect & Moisture Damage and Covered by a 5/50-Year Limited Warranty
- ✓ 2x4 Wall Framing w/Bottom & Top Plates
– Wall Studs Placed 16" On Center (The Sundance Series®)

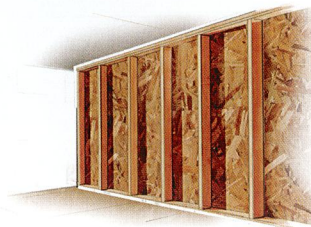

BETTER DOOR

Setting the Industry Standard for Shed Doors

- ✓ Steel Reinforced so it Won't Warp
- ✓ Patented "Sandwiched" Design
- ✓ Patented Ultra-Heavy Duty Hinges
- ✓ Rugged & Patented Locking Door Handle



BETTER ROOF

A Roof System with Layers of Strength

- ✓ Composite Shingles
– Dimensional Shingles with Lifetime Limited Warranty
- ✓ Protective Steel Drip Edge Around the Perimeter
- ✓ Roofing Underlayment (The Sundance Series®)
- ✓ Engineered 2x4 Rafters & Trusses Joined w/Steel Plates

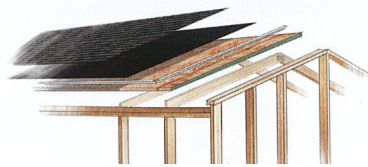

DESIGN & ORDER YOURS TODAY

Find building specs
and prices and configure
your building online at
homedepot.com/tuffshed



Hold device over
QR code with camera.
When the link appears
on your screen - click
link for available sizes
and current prices.

Text SHED to 88338 to build a quote
Call 1-888-883-3743 • See Associate

Learn more about Tuff Shed® products and receive Tuff Shed® Mobile Alerts. Msg & data rates may apply. No more than 5 msgs/month. Text HELP for help, STOP to cancel. Terms & Conditions: www.888tuffshed.com/privacy-policy/

TWO GREAT WAYS TO PAY

Finance Your Projects Now with Home Depot Credit and make
Monthly Payments.



*A permit processing fee will be automatically added to the base price of all sheds at the time of purchase. The permit processing fee is determined by the square foot of the building and the delivery zip code. This permit processing fee covers the cost of the permit and a permit pulling fee. In some cases, additional documentation, engineering or other fees may be required. In these cases, any such additional required documentation will be the sole responsibility of the customer, and any associated additional fee(s) will be added to customer's order. Fees for required permits and engineering on garages and 2nd story models are handled on a case-by-case basis. Customer is responsible for neighborhood covenants and restrictions. In some areas installation of storage buildings is not permitted. Please determine your local building rules and regulations before installing installation before considering a purchase. For delivery addresses located in High Wind Zones or other jurisdictions with known special building requirements, mandated items will be added to your order, thus increasing the building price. The specifications of the base building may vary according to the building code requirements of the jurisdiction where the job site is located. Required permits from our base building plans may increase building price. Prices are subject to change at any time without notice. Use the Tuff Shed® building configurator at homedepot.com/tuffshed and enter delivery zip code to see available products and current prices. Use of price discrepancy, prices in The Home Depot ES/S system take precedent over any outdated or out-of-market prices. *Free delivery on new buildings installed within 30 miles of The Home Depot store where purchase was made. For installation sites beyond the 30 mile radius, a delivery charge of \$2 per mile for any one-way miles will apply. *Loan product has four tiers with Term and APR subject to qualifying credit approval: 66 monthly payments at 7.42% APR; 78 monthly payments at 9.99% APR; 114 monthly payments at 19.96% APR. Monthly payments will not exceed \$20 per \$1000 spent (e.g., \$160 per month for an \$8000 purchase), APR fixed for the life of the loan. No down payment. See loan agreement for further details. LICENSES: NMLS #1416362; CT SLC-1416362; NJ MT #1501607 C22. Building heights are approximations, are rounded to the nearest inch and may vary. Clear interior sidewall heights are measured from top of floor decking to top of wall framing plates. Overall heights are measured from bottom of joist material to building peak. 6'0" door height on 6' wide models of SR-600 and KR-600. Buildings include many components (i.e. lumber, steel floor joists, windows, doors, etc.) that use nominal measurements. These measurements do not include inch marks ("). Have some variance, and have actual sizes that will always be smaller than nominal sizes. For example, a 2x4 has an approximate actual size of 1 1/2" x 3 1/2". Cancelled orders subject to a restocking fee. Additional restrictions apply.

State Contractor License #s:

AL) 17726, AR) 152480917, AZ) ROC142570, CA) 661664, CT) HIC.0652295, DE) 2018605715, FL) CBC1253645, GA) RLQA003753, IA) C000431, ID) RCE-82, IL) 104.014983, IN) TID: 0114664021, KS) 15-004751, LA) 87665, MA) 192914, MI) 2102181478, MN) BC559638, MS) R07451, MT) 147860, NE) 23180, NV) 35208, NJ) 13VH02581800, NM) 33620, NC) 63616, ND) 35559, OH) 89758117, OR) 105914, PA) PA118565, RI) 42394, SC) G112952, TN) 00058042, UT) 251787-5501, VA) 2705115435, WA) TUFFSP038RZ, WV) WV057314, WI) 1002302

©2020 Tuff Shed®, Inc. All rights reserved. Tuff Shed®, The Sundance Series®, and The Keystone Series® are registered trademarks of Tuff Shed®, Inc.

TUFF SHED®



BUILDING SPECS & INFORMATION

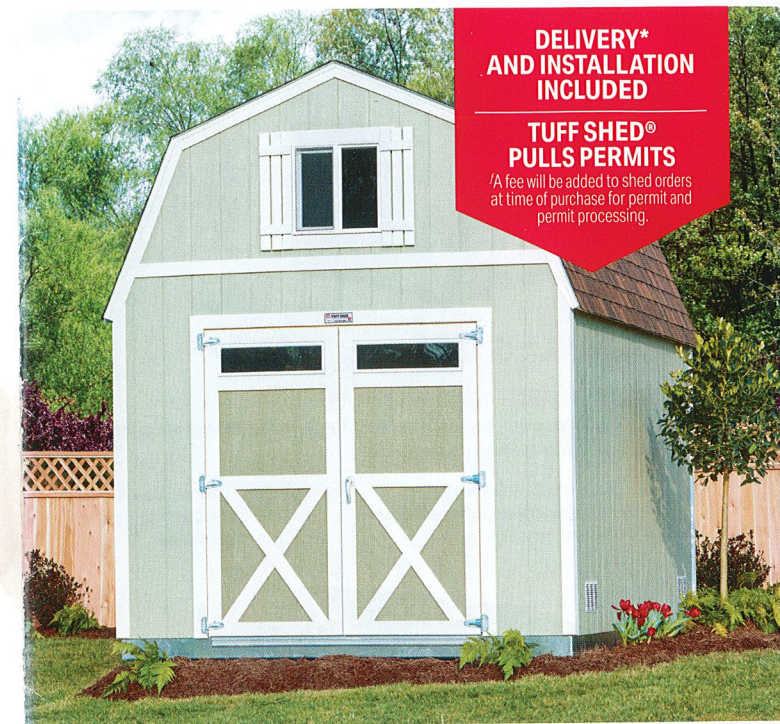

DELIVERY*
AND INSTALLATION
INCLUDED

TUFF SHED®
PULLS PERMITS

*A fee will be added to shed orders
at time of purchase for permit and
permit processing.

Hi, I'm your local Tuff Shed® Area Sales Manager.
I can help you with your building questions and orders.

Michael Pekock (919) 430-4831
mpecock@tuffshed.com



Hold device over QR code with
camera. When the link appears
on your screen - click link for
available sizes and current prices.

UPGRADES

MOST POPULAR UPGRADES

Shelving (16" & 24" deep)
Wall Vent (16"x8" or 12"x12")
Radiant Barrier Roof Decking
Double Shed Door Upgrade (3'x6'2" & 3'x6'7" tall)

WINDOWS & ACCESSORIES

Skylight (2'x2')
Window (2'x2', 3'x2', 3'x3')
Tempered Glass Transom Window (16"x8")
Shutters

SHED DOOR & ACCESSORIES

Additional Single Shed Door (4'x6'2" & 4'x6'7")
Black door hardware (single / double*)
Door Trim Upgrade (single / double*)
In-Door Transom Window (29"x8" & 41"x8")

DOOR UPGRADES (IN LIEU OF STANDARD SHED DOOR)

6 panel residential door (3'x6'8")
Residential Door w/fan-lite

RAMPS & ACCESSORIES

Steel Ramps (36" long) with sill nose
Wood Ramps (48" long) with sill nose

INTERIOR OPTIONS

Workbench (24" deep)
Overhead Loft
Pegboard Panels

VENTS

Ridge Vent
Floor Track Vent

ROOF & FLOOR OPTIONS

2nd Story Upgrade (TB-800 only)
6/12 & 8/12 Roof Pitch Upgrade⁸
6' Dormer Upgrade⁸ (10' & 12' wide)

PORCHES

Sidewall and Endwall Porch Upgrades

OTHER

Generator Rental

Availability of certain upgrades may vary by model and market. ⁸Required double door upgrade sold separately. Transom Windows are available on Sundance Series buildings only. ⁸Roof Pitch, Endwall Eave and 6' Dormer Upgrades available on Sundance Series Ranch Style Buildings Only. Dormer Upgrade requires 8/12 Roof Pitch Upgrade (sold separately).

See more upgrades at
homedepot.com/tuffshed

▶ THE TUFF SHED® DIFFERENCE

The Tuff Shed® Sundance Series of backyard buildings and garages are available exclusively through The Home Depot®. We've used our decades of experience to develop unique and patented building features, and a solid understanding of what it takes to design, manufacture and install buildings.

Since being founded in 1981, Tuff Shed® has held strong to its commitment to providing quality products and service, and has twice been named Home Depot's Service Provider of the Year (2007 and 2015).

▶ PRODUCT FEATURES INCLUDED IN TUFF SHED® BUILDINGS

Tuff Shed® storage buildings include great standard features top to bottom, with no need to pay extra for things like installation, shingles or floor system.

BETTER FLOOR

Solid Floor Systems from the Ground Up

- ✓ Heavy-Duty 3/4" Tongue & Groove Treated LP® ProStruct Flooring with SmartFinish
- ✓ Joists Designed to Resist Insect & Moisture Damage
 - 2x6 Hot Dipped Galvanized Steel w/ 40-Year Rating (The Sundance Series® Sheds)
 - 2x6 Pressure Treated Wood, Rated for Ground Contact (2-Story Buildings)
- ✓ Aluminum Door Threshold Protects the Floor Where Most Vulnerable

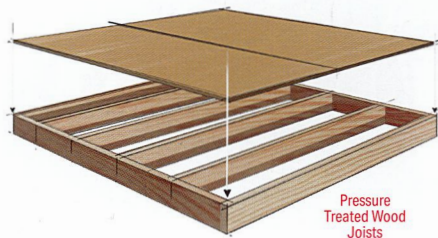
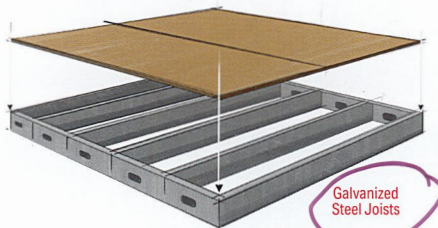

5
YEAR LIMITED WARRANTY

THE SUNDANCE SERIES® SR-600

This popular ranch style shed has been a mainstay of the Tuff Shed® product line for years. The 6'2" tall shed door (6' tall on 6' wide models) fits on the endwall. Shown here with paint upgrade.

- 2x6 Galvanized Steel Foundation
- 4'x6'2" Steel Reinforced Tuff Shed® Door
- Endwall Door Placement
- 5'8" Clear Interior Sidewall Height
- 16" On Center 2x4 Wall Framing
- 4" Block Sidewall Eave



Available with HOA Friendly Wall Height

5
YEAR LIMITED WARRANTY

THE SUNDANCE SERIES® TR-700

Our most popular model, the TR-700 offers a foot more sidewall height than the SR-600, allowing for endwall or sidewall door placement. Shown here with paint upgrade.

- 2x6 Galvanized Steel Foundation
- 4'x6'2" Steel Reinforced Tuff Shed® Door
- Endwall or Sidewall Door Placement
- 6'8" Clear Interior Wall Height
- 16" On Center 2x4 Wall Framing
- 4" Block Sidewall Eave



5
YEAR LIMITED WARRANTY

THE SUNDANCE SERIES® TR-800

The 8' sidewall height allows for more overhead room and a taller 4x6'7" door, placed on any wall. Can accommodate sidewall porch upgrade.

- 2x6 Galvanized Steel Foundation
- 4'x6'7" Steel Reinforced Tuff Shed® Door
- Endwall or Sidewall Door Placement
- 7'8" Clear Interior Sidewall Height
- 16" On Center 2x4 Wall Framing
- 6" Block Sidewall Eave



Shown with optional upgrades, including paint, windows, shutters, double door, door trim and in-door transom upgrades.

BARN STYLE SHEDS

5
YEAR LIMITED WARRANTY

THE SUNDANCE SERIES® TB-600

The TB-600 provides a barn style roof with The Sundance Series® upgraded features. Shown here with paint upgrade.

- 2x6 Galvanized Steel Foundation
- 4'x6'2" Steel Reinforced Tuff Shed® Door
- Endwall Door Placement
- 5'8" Clear Interior Sidewall Height
- 16" On Center 2x4 Wall Framing
- 3" Flat Sidewall Eave



5
YEAR LIMITED WARRANTY

THE SUNDANCE SERIES® TB-700

The TB-700 features 7' tall sidewalls, allowing for more overhead room and door placement options. Shown here with paint upgrade.

- 2x6 Galvanized Steel Foundation
- 4'x6'2" Steel Reinforced Tuff Shed® Door
- Endwall or Sidewall Door Placement
- 6'8" Clear Interior Sidewall Height
- 16" On Center 2x4 Wall Framing
- 3" Flat Sidewall Eave

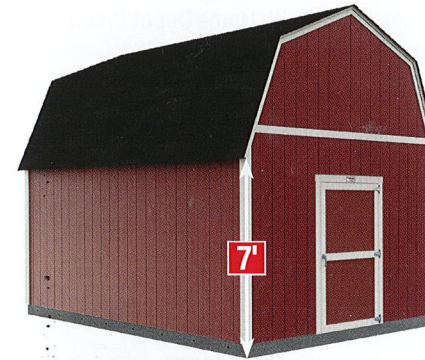

LEAN-TO STYLE SHEDS

5
YEAR LIMITED WARRANTY

THE SUNDANCE SERIES® LEAN-TO

This model has its roof peak along one of the sidewalls instead of the center of the building. Door size varies on this model based on placement. Shown here with paint upgrade.

- 2x6 Galvanized Steel Foundation
- 6' Tall Steel Reinforced Tuff Shed® Door
- Endwall or Sidewall Door Placement
- 6'4" Clear Interior Sidewall Height
- 16" On Center 2x4 Wall Framing
- 4" Block Sidewall Eave (front)



PLANNING DEPARTMENT

AUG 05 2024

RECEIVED

5
YEAR LIMITED WARRANTY

THE SUNDANCE SERIES® TB-800

Maximize your storage space with another foot of sidewall height and more overhead room. The 8' sidewalls allow for a 4'x6'7" door placed on any wall. Shown here with paint upgrade.

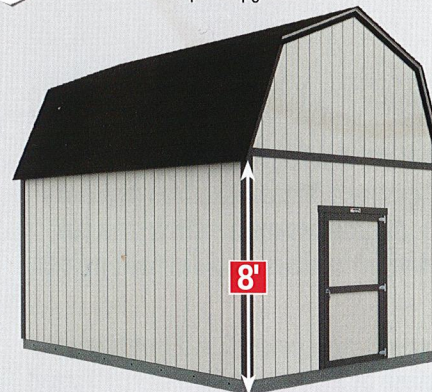

SINGLE FLOOR

- 4'x6'7" Steel Reinforced Tuff Shed® Door
- Endwall or Sidewall Door Placement
- 7'8" Clear Interior Sidewall Height
- 16" On Center 2x4 Wall Framing
- 3" Flat Sidewall Eave (Single Floor)

This model can also accommodate porch and 2nd Floor upgrades. Open Floor view shown here.



2ND FLOOR UPGRADE WITH STAIRS

- 6" Boxed Eaves
- 2x6 Treated Wood Foundation

Concrete Foundation Suggested

GARAGES

5
YEAR LIMITED WARRANTY

THE SUNDANCE SERIES® RANCH GARAGE

Standard and custom sizes and designs to match the architecture of your home. Includes standard overhead door up to 16' wide and a 6-panel 3'x6'8" residential door. Shown here with paint upgrade. Concrete work **not included** in price.

- 3'x6'8" 6 Panel Residential Door
- Standard Overhead Door (up to 16'w & 7'h)
- 8'1" Clear Interior Wall Height
- 16" On Center 2x4 Wall Framing
- 12" Soffited Sidewall Eaves (Optional on Endwalls)



Concrete Foundation Required

MAKE IT YOUR OWN WITH THESE GREAT UPGRADES

Buildings shown with optional upgrades.

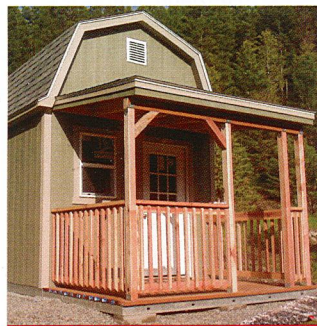

Endwall Porch & Eaves



Custom Roof Pitch, Eaves and Gutters



Endwall Eaves, 8/12 Roof Pitch Upgrade, Dormer, Double Door & Wood Ramps



Custom Wall Height & Roof Pitch

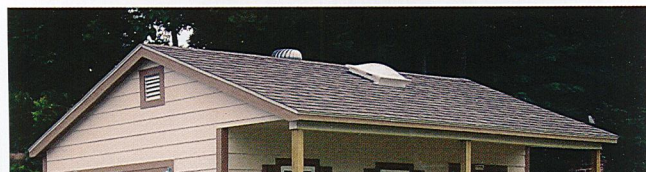

PAINT

Tuff Shed® offers 30 colors of quality paint. Colors shown here are approximations. Actual paint swatches available inside the paint department or at homedepot.com/tuffshed

				
Delicate White #1001-1	Tundra Frost #1009-1	Cherokee Red #13-02	Brick Dust #1056-7	Hunt Club Red #16-29
				
Warm Up #1067-6	Cool Clay #1071-5	Bulletin Board #12-04	Waves of Grain #12-07	Southern Breeze #1097-2
				
Smoky Slate #1028-4	Autumn Gray #1028-5	Licorice #1009-7	Night Watch #1145-7	Seastone #10-11
				
Sheffield Gray #1041-6	Goblin #1040-7	Ground Coffee #1076-7	Notorious #1074-4	Cocoa Cream #1079-3
				
Hat Box Brown #1085-6	Almond Brittle #1095-3	Maison De Champagne #15-01	Gray By Me #1008-4	Ghost Writer #1007-3



Myrtle Grove 10PM

28412

W...



Myrtle Grove 10PM

28412

Shop All Services DIY Log In

Home / Doors & Windows / Exterior Doors / Patio Doors

Internet # 202082338 Model # 97758 Store SKU # 694071 Store SO SKU #511213

Masonite

72 in. x 80 in. Primed White Steel Prehung Right-Hand Inswing Full Lite Clear Glass Patio Door with Brickmold

★★★★★ (55) Questions & Answers (41)

226

Live Chat

Feedback

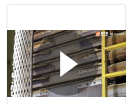

Hover Image to Zoom

Share Print

\$627⁰⁰

RECEIVED

By Megan Bacik at 2:08 pm, Aug 05, 2024

Pay \$577.00 after \$50 OFF your total qualifying purchase upon opening a new card. [Apply for a Home Depot Consumer Card](#)

- Steel panel construction offers security and durability
- Full Lite clear glass insert is energy efficient
- French door unit features primed wood frame
- [View More Details](#)

Myrtle Grove Store

✓ 3 in stock Aisle 26, Bay 011

Color/Finish: Primed White



Common Door Size (WxH) in.: 72 x 80

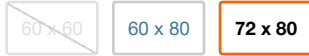

Door Handing: Right-Hand/Inswing



Pickup at Myrtle Grove

Delivering to 28412

<p>Pickup</p> <p>Today</p> <p>3 in stock</p> <p>FREE</p>	<p>Delivery</p> <p>Tomorrow</p> <p>3 available</p>
---	---

Get it as soon as tomorrow. Schedule your delivery in checkout.

Get Expert Door Installation
 A local pro will take care of the job for you

Request door installation service

[What to Expect](#)

RECEIVED
 By Megan Bacik at 2:08 pm, Aug 05, 2024

Have Questions? We're Here to Help.

Speak to a Virtual Associate about Doors or Windows today.
 Monday - Friday from 9AM - 11PM ET &
 Saturday - Sunday from 9AM - 9PM ET.

Request Appointment [What to Expect](#)

Or call 1-833-HD-APRON(1-833-432-7766)

- 1 + [Add to Cart](#)

Free & Easy Returns In Store or Online
 Return this item within 90 days of purchase. [Read Return Policy](#)

Frequently Bought Together

Live Chat
Feedback

CURRENT ITEM

Select



Masonite
72 in. x 80 in. Primed White Steel Prehung...
★★★★★ (55)
\$627⁰⁰



Select



Masonite
36 in. x 80 in. Premium 9 Lite Primed White...
★★★★★ (107)
\$339⁰⁰



Select



Masonite
36 in. x 80 in. Craftsman 6 Lite Rig...
★★★★★ (133)
\$429⁰⁰



Select



Kwikset
Juno Satin Nickel Exterior Entry Door...
★★★★★ (3361)
\$48⁹⁷ ~~\$68.47~~ Save \$11.50 (19%)



Select



Masonite
72 in. x 80 in. x Replacement S...
★★★★★ (45)
\$178⁰⁰

Live Chat
Feedback

Subtotal: **\$1625⁶²**

Add 6 Items to Cart

Product Details

About This Product

Bring the beauty of the outdoors inside with the energy-efficient Masonite 72 in. x 80 in. Primed Prehung right-Hand inswing Full Lite Patio Door with Brickmold. Providing natural light and elegant design, the clear, multi-pane insulated glass is treated with a Low-E coating that reflects heat out of the home in the summer and locks in heat during the winter. Plus the premium polyurethane insulation and weatherstripping are designed to let the beauty of nature in, but the weather out - resulting in lower heating and cooling bills. Constructed of reinforced steel for strength and durability, this door is the perfect complement to your outdoor decor and can help expand your living space when used for decks, patios and balconies.

Highlights

- High-quality steel provides strength and security
- Steel reinforced door features energy saving polyurethane door core
- High performance compression weatherstripping helps to seal out drafts
- Low-E tempered glass helps keep you comfortable in any season
- Smooth, primed white surface ready for painting and decorating
- Screen kits available for all inswing units - sold separately
- Rot-resistant bottom rail made of high-performance composite materials
- Patio door slabs are double bored for lockset - not included
- Patio door comes fully assembled with hinges, frame, aluminum sill and weatherstripping
- From outside, open towards the inside of the house with the hinges on the right
- PROFESSIONAL DOOR INSTALLATION - CALL 1-888-654-2692 to get started with a free in-home consultation or [learn more about our trusted door installations service.](#)
- [Speak to an Associate about Doors and Windows.](#) Call 1-833-HDAPRON (432-7766) for free design, purchase and installation help daily from 9AM – 9PM EST.
- Click here to learn more about [Eco Options and Energy Efficiency](#)
- [Return Policy.](#)
- California residents [see Prop 65 WARNINGS](#)

RECEIVED
By Megan Bacik at 2:08 pm, Aug 05, 2024

Product Information

Internet # 202082338

Model # 97758

Store SKU # 694071

Store SO SKU #511213

Additional Resources

[Shop All Masonite](#)

From the Manufacturer

- [Installation Guide](#)
- [Return Policy](#)

Live Chat

Feedback

Specifications

Dimensions

Actual Door Height (in.)	81.75 in
Actual Door Thickness (in.)	4.56
Actual Door Width (in.)	73.8 in
Door Height (in.)	80 in
Door Thickness (in.)	1.75 in
Door Width (in.)	72 in
Nominal Door Height (in.)	80 in
Nominal Door Thickness (in.)	2 in
Nominal Door Width (in.)	72 in
Rough Opening Height (in.)	80 in
Rough Opening Width (in.)	72 in

RECEIVED

By Megan Bacik at 2:08 pm, Aug 05, 2024

Details

Bore Type	Double Bore
Color Family	White
Color/Finish	Primed White
Core Type	Solid Core
Door Configuration	Double Door
Door Glass Insulation	Triple Pane
Door Handing	Right-Hand/Inswing
Door Type	French Patio Door
Features	Brickmold, Insulated, Lockset Bore (Double Bore), Tempered Glass, Weatherstripping
Finish Type	Primed
Frame Material	Wood
Hinge Type	Standard
Included	Instructions, No Additional Items Included
Material	Steel
Number of Lites	1 Lite

Product Weight (lb.)	250 lb
Returnable	90-Day

Warranty / Certifications

Energy Star Qualified	Not Qualified
Manufacturer Warranty	Limited Lifetime Warranty

How can we improve our product information? Provide feedback.

Questions & Answers

41 Questions

RECEIVED
By Megan Bacik at 2:09 pm, Aug 05, 2024

Customer Reviews

4.3 out of 5 ★★★★★ (55)

Live Chat
Feedback

Sponsored



TALK & LISTEN FROM ANYWHERE, ANYTIME

Find the Right Nest Smart Doorbell for Your Home

Shop Now

More from Masonite



Masonite
 72 in. x 80 in. Primed White Steel Prehung Left-Hand Inswing Full Lite Clear Glass...

★★★★★ (32)

\$627⁰⁰

Add to Cart

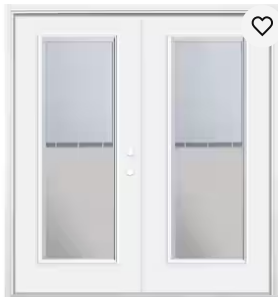

Masonite
 72 in. x 80 in. Primed Prehung Left-Hand Inswing Mini Blind Steel Patio Door with Brick Mold

★★★★★ (107)

\$898⁰⁰ ~~999.00~~

Add to Cart



Masonite
 72 in. x 80 in. Ultra White Steel Prehung Right-Hand Inswing Full Lite Clear Glass Patio Do...

★★★★★ (15)

\$2078⁰⁰

Add to Cart

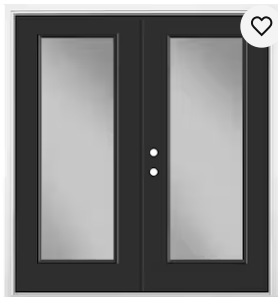

Masonite
 72 in. x 80 in. Jet Black Steel Prehung Right-Hand Inswing Full Lite Clear Glass Patio Do...

★★★★★ (15)

\$2078⁰⁰

Add to Cart



Masonite
 72 in. x 80 in. Canyon Steel Prehung Right-Hand Inswing Full Lite Clear Glass Patio Do...

★★★★★ (15)

\$1470⁴⁰

Add to Cart

< 1/3 >

You Might Also Need



Your Delivery Zip: **28401** () | Find a Store (/locate/)



Premier PRO Series™

[ALL PRODUCTS \(/PRODUCTS/#/ALL/\)](/PRODUCTS/#/ALL/)

DETAILS

[SPECIFICATIONS](#)

[SIZE & PRICING](#)

BUILD-A-QUOTE

[\(/PRODUCTS/#/CONFIGURATOR/PREMIER%20PRO%20RANCH/\)](/PRODUCTS/#/CONFIGURATOR/PREMIER%20PRO%20RANCH/)

[\(/warranty\)](/warranty)

★ GOOD ★ BETTER ★ **BEST**

RECEIVED

By Megan Bacik at 2:09 pm, Aug 05, 2024



[Back to Parent](#)

Timberline HDZ®

GAF's #1 selling - shingle. High Definition® color blends backed by strong warranties.







★★★★★ 4.8 (18734) [WRITE A REVIEW](#)

[Find a Contractor](#)

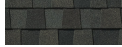
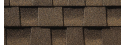

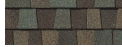
[All Products](#) [Your Area](#)

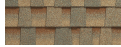
[Find a contractor](#)

-  Pewter Grav
-  Appalachian Skv
-  Barkwood
-  Birchwood
-  Biscayne Blue
-  Cedar Falls
-  **Charcoal**
-  Copper Canvon
-  Driftwood

Jump to [Overview](#)

About Timberline HDZ® Shingles

Get advanced roof protection from eave to ridge. The technologies incorporated into Timberline HDZ® shingles are the keys to unlocking both the 15-Year WindProven™ Limited Wind Warranty and the 25-Year StainGuard Plus™ Algae Protection Limited Warranty.

[Expand to read more](#) ▼

RECEIVED
By Megan Bacik at 2:09 pm, Aug 05, 2024



Go beyond expectations with Timberline UHDZ® Shingles

Timberline UHDZ® shingles offer a combination of beauty and benefits that goes beyond any GAF shingle you've been able to choose before. Our patented Dual Shadow Line helps your new Timberline® UHDZ™ Shingles look their very best from every angle, all day long. And with 10% more Time-Release Algae-Fighting Technology, GAF can offer an algae protection warranty longer than we've ever offered.

[See shingles](#)

RECEIVED
By Megan Bacik at 2:10 pm, Aug 05, 2024

Specs & Codes

Specifications (All Dimensions Are Nominal)	
Pieces/Square	64
Bundles/Square	3
Nails/Square ¹	256
Exposure	5 5/8"
Dimensions	13 1/4" x 39 3/8"

Applicable Standards & Protocols
<ul style="list-style-type: none"> • Fire - UL Listed to ANSI/UL 790 Class A • Wind - ASTM D7158, Class H

Applicable Standards & Protocols

- Wind - ASTM D3161, Class F
- National - ASTM D3018, Type 1
- National - ASTM D3462**
- National - Classified in accordance with ICC-ES AC438
- Regional - Miami-Dade County Product Control Approved***
- Regional - State of Florida Approved
- Regional - Texas Department of Insurance Listed
- Regional - ICC-ES ESR- 1475****
- Regional - ICC-ES ESR- 3267
- Special Feature - Cool Roof Rating Council (CRRC) Rated*****
- Special Feature / Regional - CA Title 24
- Regional - CSA A123.5*****

**ASTM D3462 - Periodically tested by independent and internal labs to ensure compliance with ASTM D3462 at time of manufacture. Applies to only some plants that make Royal Sovereign® Shingles and Marquis WeatherMax® Shingles. Applies to White only for Royal Sovereign® Shingles.

***Miami-Dade County Product Control Approved - Applies to some plants only that make Timberline® UHDZ™ Shingles, Royal Sovereign® Shingles and Marquis WeatherMax® Shingles. Applies to White only for Royal Sovereign® Shingles.

****ICC-ES ESR- 1475 - Applies to some plants only that make Royal Sovereign® Shingles and Marquis WeatherMax® Shingles. Applies to White only for Royal Sovereign® Shingles.

*****Cool Roof Rating Council (CRRC) Rated - Applies to White, Copper Canyon, Birchwood, and Golden Amber only for Timberline HDZ®. Applies to White only for Royal Sovereign®.

*****CSA A123.5 - Applies to some plants only that make Timberline HDZ®, Timberline® NS, and Timberline AS II®.

*****City of LA / LA County - Applies to the following shingles/colors: Timberline HDZ® White, Timberline® NS Arctic White, Timberline HDZ® RS Birchwood, Golden Amber, Sandalwood, and Sagewood, Grand Sequoia® RS Sagewood, and Sandalwood, Royal Sovereign® White.

Product Documentation

[View All Documents](#)

DuraGrip™ WindProven Technology - RESGN751

Data Sheets



PDF

Laminated Shingles SDS - 2093

Safety Data Sheets



RECEIVED
By Megan Bacik at 2:10 pm, Aug 05, 2024

PDF

LayerLock™ Technology - RESTZ114

Data Sheets

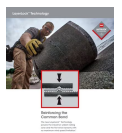

PDF

Timberline HDZ® Shingles - RESTZ102

Data Sheets



PDF



Timberline HDZ®

★★★★★
4.8 (18734)

\$\$



Timberline UHDZ®

★★★★★
4.9 (83)

\$\$\$



Timberline® NS

★★★★★
4.8 (495)

\$

Shingle Type

Timberline Lifetime Shingles

Timberline Lifetime Shingles

Timberline Lifetime Shingles

Shingle Construction

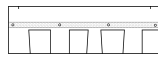
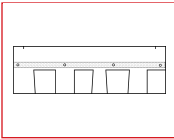

Made in the USA With Domestic and Imported Materials



Lifetime Limited Warranty†



WindProven Limited Warranty¹



LayerLock® Technology



Algae Protection

25-year StainGuard Plus™ Limited Warranty

30-year StainGuard Plus™ PRO Limited Warranty

10-Year StainGuard® Protection Limited Warranty

Title 24³



RECEIVED
By Megan Bacik at 2:10 pm, Aug 05, 2024

Impact Resistance Rating



Parts of a GAF roofing system

Residential warranties

Select Tab

Rooftop accessories

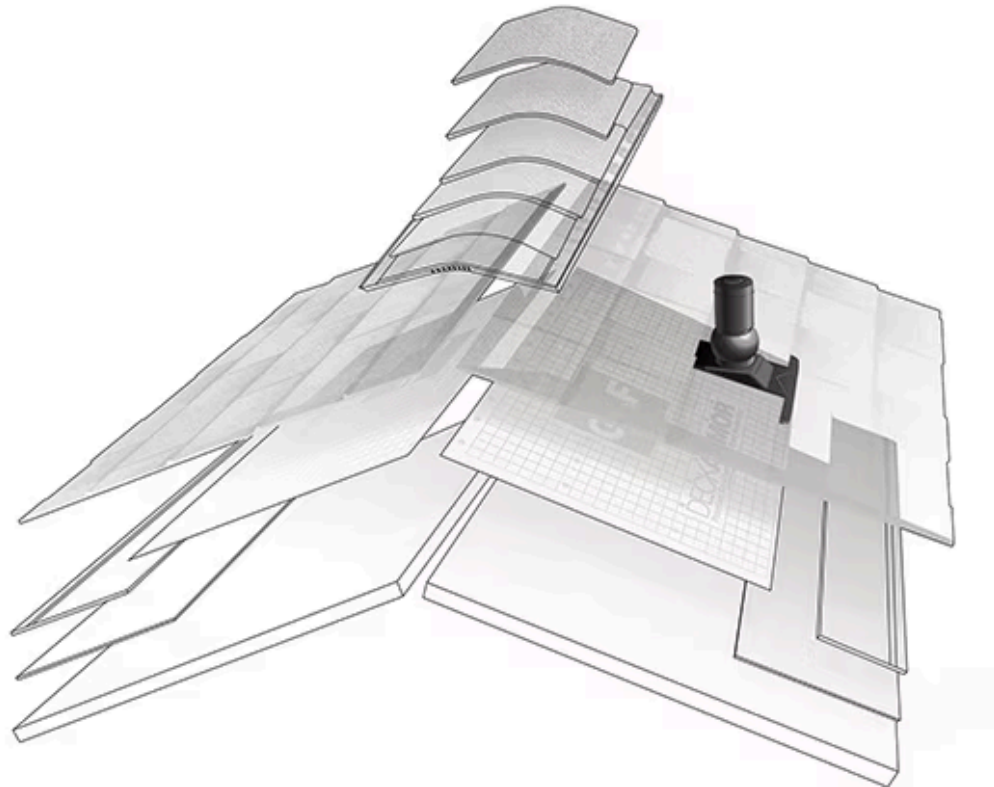

Rooftop accessories

Specialty roofing accessories designed to enhance the performance of your roofing system.

See products

RECEIVED

By Megan Bacik at 2:10 pm, Aug 05, 2024

Reviews

Rating Snapshot

Select a row below to filter reviews.

5 stars		16981
4 stars		1096
3 stars		242
2 stars		64



RECEIVED

By Megan Bacik at 2:10 pm, Aug 05, 2024

EXPLORE SIDING & TRIM

Select a link

PANEL & VERTICAL SIDING

Features shiplap edges with alignment bead for easier installation, along with a groove available placed 8 o.c. or 4 o.c.

AVAILABLE PROFILES



Pebbled Stucco Panel Siding

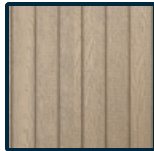

Cedar Texture Groove Panel Siding



Cedar Texture No-Groove Panel Siding

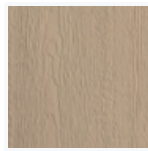

Cedar Texture Vertical Siding

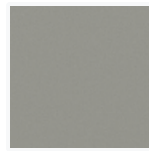

Brushed Smooth Vertical Siding



See It In Action

★★★★★ (37)

REQUEST A QUOTE >

EXPERTFINISH COLORS >



Cedar Texture Groove Panel Siding (Pictured primed and ready to paint)

Get LP SmartSide ▾

- Homeowners >
- FIND A CONTRACTOR**
- Professionals >

Looking for color? Select LP SmartSide products are available in 16 ExpertFinish® prefinished colors.

Explore color to get inspired, or download the complete list.



Advanced Durability

Engineered wood technology offers superior protection against the elements.



16 Foot Length

Can allow for faster installation and less jobsite waste.



Fewer Seams

Can result in a cleaner, more elegant look.



Industry-Leading Warranty

Backed by a 5/50-year limited warranty.



Award-Winning

Green Builder Media's Most Sustainable Siding Supplier per the 2022 Brand Index.

RECEIVED

By Megan Bacik at 2:10 pm, Aug 05, 2024

Get LP SmartSide ▼

- Homeowners ▶
FIND A CONTRACTOR
- Professionals ▶



Lap Siding



Panel & Vertical Siding



Trim & Fascia

RECEIVED

By Megan Bacik at 2:10 pm, Aug 05, 2024

PRODUCT	LENGTHS AVAILABLE	GROOVE?	GROOVE WIDTH	WIDTHS AVAILABLE	MINIMUM THICKNESS	SUBSTRATE	COLORS
PANEL SIDING							
38 Series Cedar Texture Panel	6, 7, 8, 9, 10, 12 ft (1.8, 2.1, 2.4, 2.7, 3, 3.7 m)	8 in. o.c. (203 mm)	3/8 in (10 mm)	48.56 in (1234 mm)	.354 in (8.9 mm)	Strand	Primed
38 Series Cedar Texture Panel No Groove Shiplap Edge	8, 9, 10 ft (2.4, 2.7, 3 m)	No Groove	N/A	48.56 in (1234 mm)	.354 in (8.9 mm)	Strand	Primed
38 Series Cedar Texture Panel No Groove Shiplap Edge - ExpertFinish	8, 10 ft (2.4, 3 m)	No Groove	N/A	48.56 in (1234 mm)	.354 in (8.9 mm)	Strand	16 ExpertFinish Colors
38 Series Cedar Texture Panel No Groove Square Edge	8 ft (2.4 m)	No Groove	N/A	48.56 in (1234 mm)	.354 in (8.9 mm)	Strand	Primed
38 Series Cedar Texture Panel No Groove Square Edge - ExpertFinish	8 ft (2.4 m)	No Groove	N/A	48.56 in (1234 mm)	.354 in (8.9 mm)	Strand	16 ExpertFinish Colors
38 Series Cedar Texture Siding and Soffit Panel No Groove	8 ft (2.4 m)	No Groove	N/A	47.88 in (1216 mm)	.354 in (8.9 mm)	Strand	Primed
76 Series Cedar Texture Panel	8, 9, 10 ft (2.4, 2.7, 3 m)	4 or 8 in. o.c. (102 or 203 mm)	3/8 in (10 mm)	48.56 in (1234 mm)	.418 in (10.6 mm)	Strand	Primed
76 Series Cedar Texture Panel No Groove Shiplap Edge	8, 9, 10 ft (2.4, 2.7, 3 m)	No Groove	N/A	48.56 in (1234 mm)	.418 in (10.6 mm)	Strand	Primed
190 Series Cedar Texture	8, 9, 10 ft (2.4, 2.7, 3 m)	8 in. o.c. (203 mm)	3/8 in (10 mm)	48.56 in (1234 mm)	.578 in (14.6 mm)	Strand	Primed
190 Series Cedar Texture Panel No Groove Shiplap Edge	8, 9, 10 ft (2.4, 2.7, 3 m)	No Groove	N/A	48.56 in (1234 mm)	.578 in (14.6 mm)	Strand	Primed
VERTICAL SIDING							
38 Series Cedar Texture Vertical Siding	16 ft (4.9 m)	No Groove	N/A	15.94 in (405 mm)	.354 in (8.9 mm)	Strand	Primed
38 Series Cedar Texture Vertical Siding - ExpertFinish	16 ft (4.9 m)	No Groove	N/A	15.94 in (405 mm)	.354 in (8.9 mm)	Strand	16 ExpertFinish Colors

Why Choose LP SmartSide ExpertFinish Trim & Siding



RECEIVED
 By Megan Bacik at 2:10 pm, Aug 05, 2024

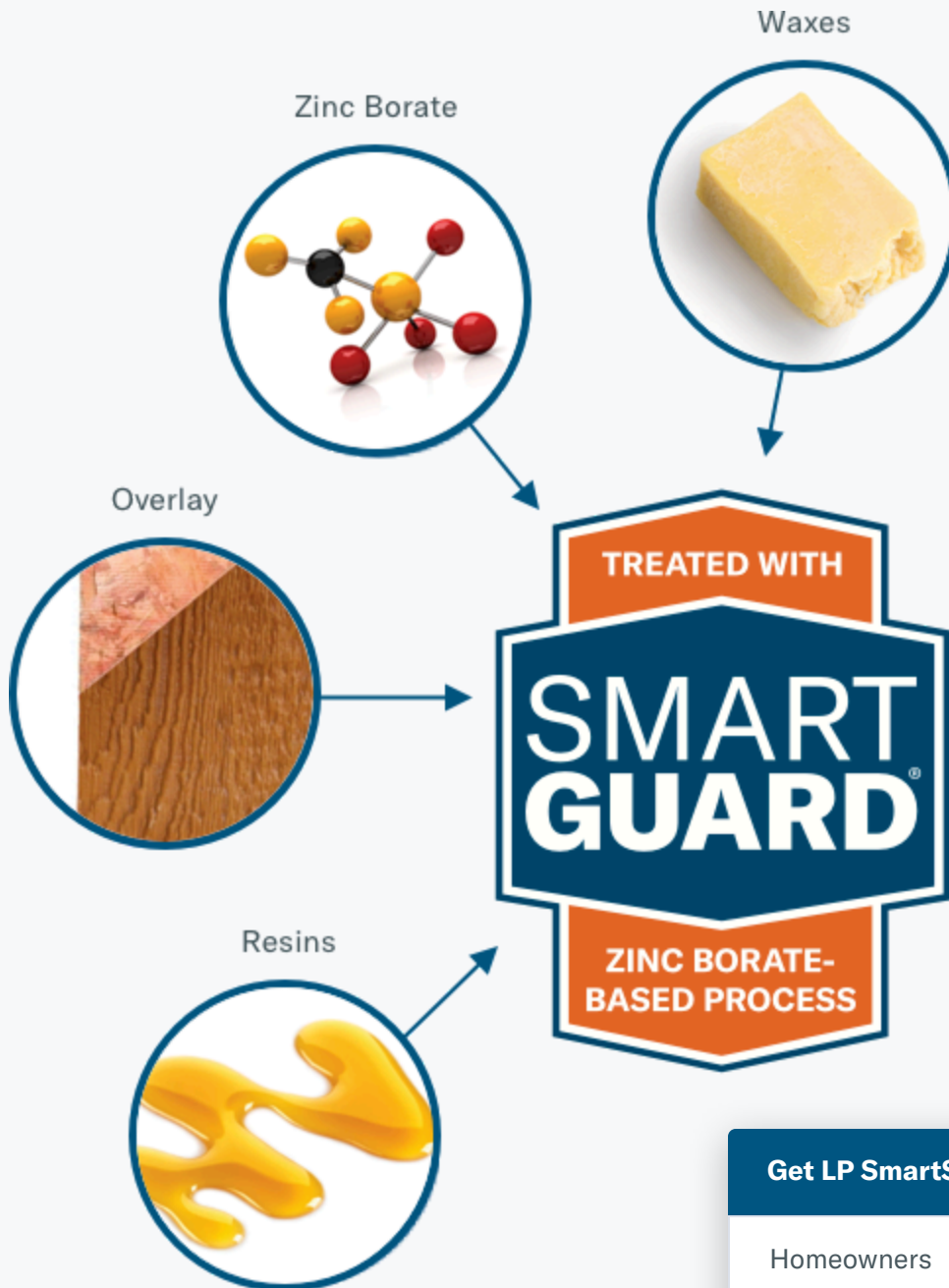

Get LP SmartSide ▾

Homeowners >
FIND A CONTRACTOR

Professionals >